

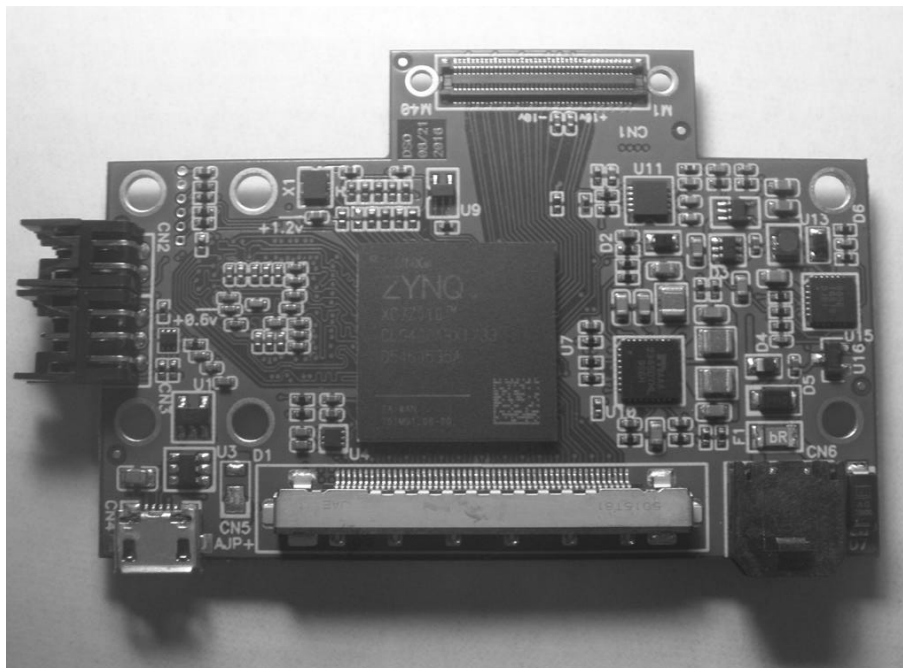

Ajile DMD Controller Hardware User's Guide

AJL-ADB-03-02

Draft Version 1.0 – March 23rd, 2018



Revision History

March 23 rd , 2018	DSO	Initial Release

Table of Contents

1.0 - INTRODUCTION	4
1.1 - Board Overview.....	4
1.2 - Basic Installation and Mounting	5
1.3 - Cooling.....	5
1.4 - Overview of External Connections	7
1.4.1 - DMD connector	7
1.4.2 - LED connector	7
1.4.3 - Trigger connector	7
1.4.4 - USB connector.....	8
1.4.5 - AJP+	8
1.4.6 - AJP Power.....	8
1.4.7 - microSD Card.....	8
1.5 - Indicators	9
1.5.1 - Overview of indicators	9
1.5.2 - Boot-mode indicators – normal startup.....	9
1.5.3 - USB Fault indicator	10
1.5.4 - User indicators	10
1.6 - Thermal monitoring.....	10
1.7 - Power monitoring for DMD power sequencing	10
2.0 - BOARD CONNECTOR USAGE INFORMATION	11
2.1 - Board Connector Details.....	11
2.1.1 - CN1 - DMD connector	11
2.1.2 - CN2 - LED Board connector	11
2.1.3 - CN3 - Trigger connector	11
2.1.4 - CN4 - USB2 OTG interface.....	13
2.1.5 - CN5 - AJP+ interface.....	13
2.1.6 - CN6 - Power.....	15
2.2 - SD Card connector.....	15
3.0 – FIELD TROUBLESHOOTING.....	16
4.0 - SPECIFICATIONS	17

1.0 - Introduction

1.1 - Board Overview

Congratulations on your choice of the Ajile AJL-ADB-03-02 DMD4500 controller board. This controller board is a complete solution capable of reliably driving a Texas Instruments DMD4500 digital micromirror array at high speeds in conjunction with a Xilinx Zynq CPU core. Utilizing a tightly-knit memory fabric, fast DMD operation is possible with usable AJP/AJP+ data bandwidths up to 1.6 GB/sec for low-latency, high-speed DMD control. Provisions for flexible low-latency triggers, an Ajile LED controller interface (for projector usage), and a USB 2.0 OTG interface for host/device connectivity are all included for maximum flexibility. Operating from a single +5 VDC power supply, all required voltages necessary for DMD and Zynq operation are internally generated to ensure consistent, glitch-free DMD operation in reliable active service.

Overview of Ajile DMD Controller Board Features

- *Zynq 7010/7020 (FBGA400)*
- *1GB of LPDDR2-800 PS memory*
- *256MB bootable QSPI flash*
- *Integrated Zynq power generation/monitoring*
- *Integrated DMD power generation/monitoring*
- *Bootable microSD card interface*
- *DMD4500 interface for driving a DMD mirror array (Lightcrafter-compatible)*
- *High-speed AJP+ interface (1.6GB/sec)*
- *LED controller board interface (6-channels/2 controller maximum)*
- *2 PL-based high-speed triggers (bi-directional)*
- *2 PS-based high-speed triggers (bi-directional) with alternate MIO peripheral mappings*
- *USB2.0-OTG interface allowing board use as both USB host or USB device*
- *A variety of status indicators clearly showing board state*
- *Operates from a single +5v supply for all functionality, with flexible power options*
- *Extremely compact size*

The form factor of this board is designed for highest component and power density, and features a mounting pattern compatible with other Ajile system boards allowing for convenient board-stacking when used as part of a multi-board module. In addition, if the board is booted with a microSD card inserted in the on-board card interface, the device will automatically reconfigure itself to boot from the memory card. If the board is booted with no memory card, the system will automatically revert to booting from the on-board flash memory. This feature allows for flexible field-recovery or diagnostic options, depending on the specifics of software implementation used to perform this operation.

The Ajile AJL-ADB-03-02 is designed for reliable, high-performance service in any application utilizing a DMD4500 digital micromirror array, and provides for complete state-of-the-art DMD operational performance in an attractive compact size.

1.2 - Basic Installation and Mounting

Installation and wiring of the Ajile DMD controller is often driven by proximity to the DMD4500 device as this board connects to the flex cable on this assembly. Mounting should be such that the flex cable is long enough to reach the DMD connector on the controller board.

Six (6) mounting holes are provided to suitably affix the board to a support plate or chassis in the end-use device. Note that 4 of these holes are in a standard configuration to allow for stacking of Ajile boards for prototyping or production. Overall board dimensions and hole locations are as noted below:

Ajile DMD Controller, Mechanical Dimensions for Mounting, Top View

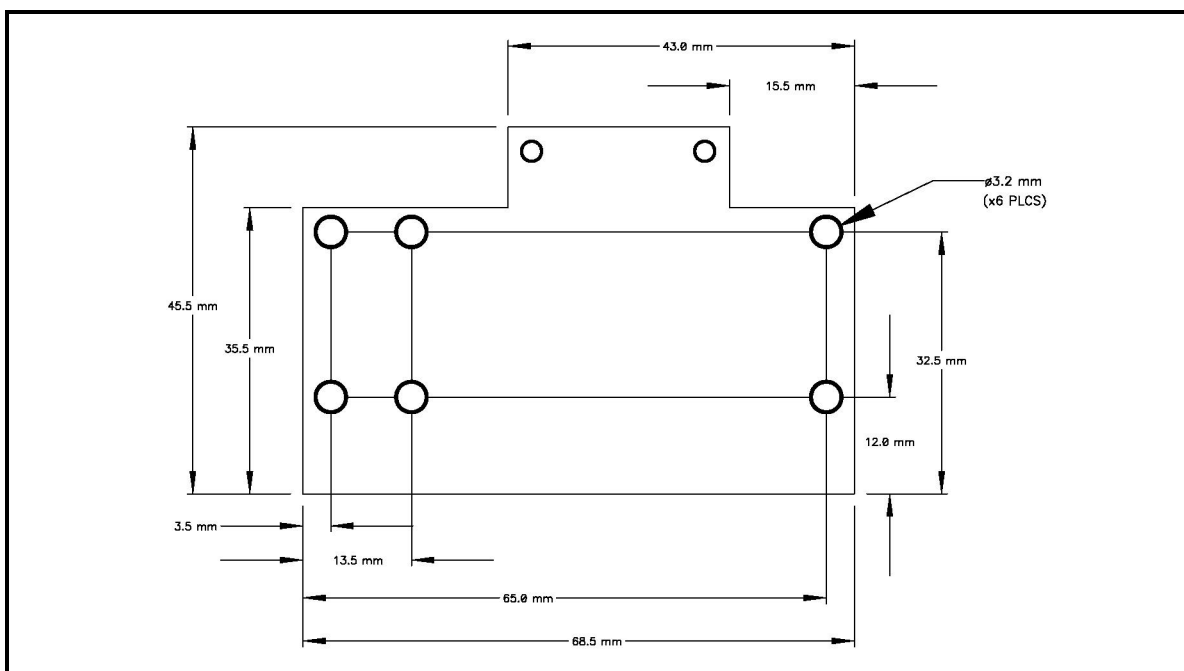

Note that these dimensions are circuit-board dimensions, and do not take into account peripheral space required for connectors. Mounting should also take into consideration overall cooling considerations and issues. These are noted below.

1.3 - Cooling

The Ajile DMD controller board can work with both active and passive cooling depending on environmental conditions and system load in the end-use device. If adequate convective airflow is available, a forged heatsink is adequate for cooling. For applications that require additional cooling, active cooling must be used in addition to a forged heatsink. This is normally provided by a fan, which can be powered from a number of sources. Suitable heatsinks that can be used in either case are as follows, depending on cooling required:

Ajile Recommended Forged Heatsinks for Zynq Processor:

Low-Efficiency	Mid-Efficiency	High-Efficiency
CTS APF19-19-06CB/A01 Resistance: 7.1 C/W @ 200 LFM Fin Height: 6.35mm	CTS APF19-19-10CB/A01 Resistance: 5.3 C/W @ 200 LFM Fin Height: 9.4mm	CTS APF19-19-13CB/A01 Resistance: 4.0 C/W @ 200 LFM Fin Height: 12.7mm

For systems that utilize an Ajile carrier board as part of the system, 12v fan power can be provided from this source provided that the carrier and DMD boards are in close proximity. For DMD boards that utilize an Ajile LED controller for illumination, a single 12v two-speed fan control channel is available as part of this expansion board at the LED controller. If two LED controllers are used, an additional fan controller channel is available from the second board.

For systems that do not use either an LED board or are separated from the Ajile carrier board, a 5v fan can be connected to the power pins on the trigger connector for cooling. The Ajile trigger board has a pass-through connector allowing access to all of the available triggers while still exposing a trigger connector to allow for a cooling fan to connect. Note that total available board power at 5v is 1.1A, and any fan power drawn from the trigger connector will impact maximum available power up to this limit.

1.4 - Overview of External Connections

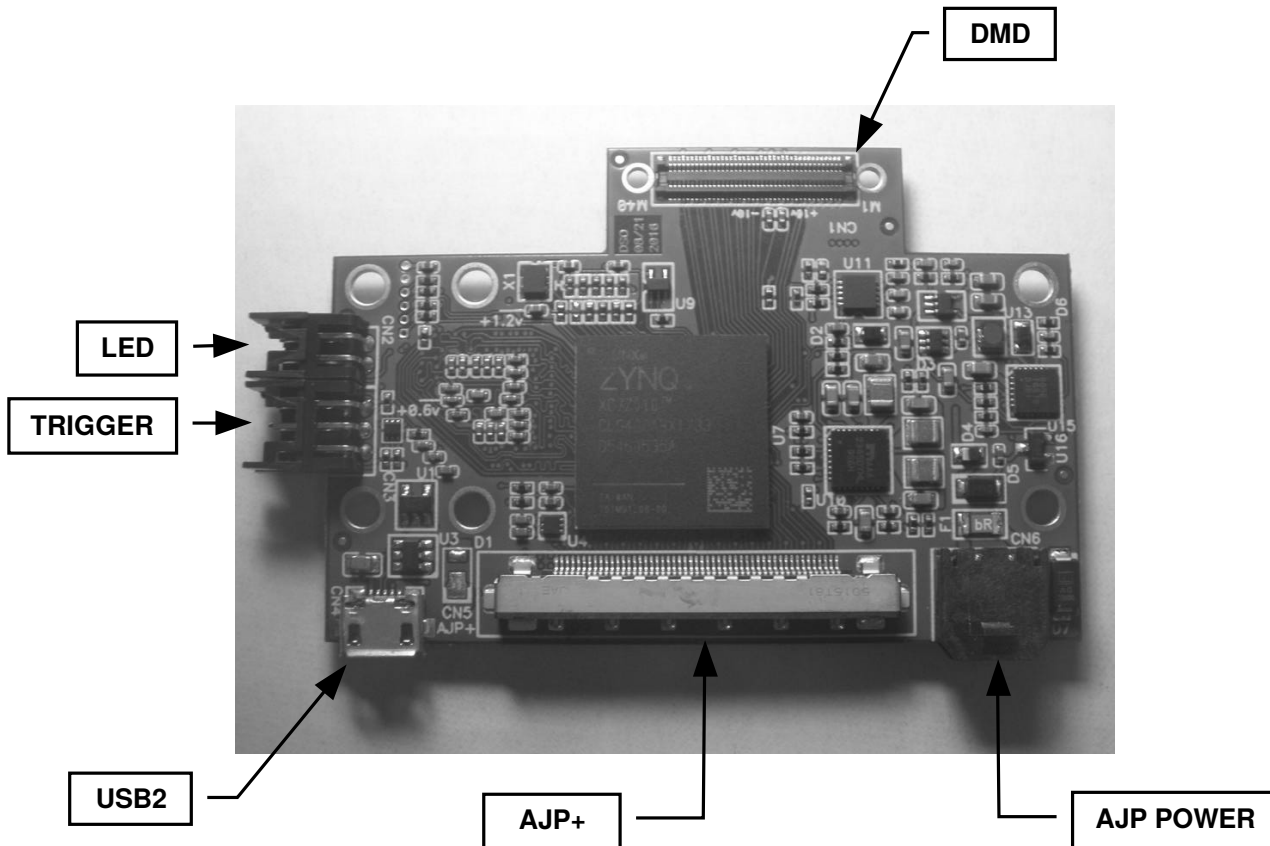

1.4.1 - DMD connector

The Ajile DMD controller uses a Lightcrafter-compatible DMD connector, allowing use of this controller with existing systems through a simple retrofit or as part of new installations. Once connected, the connector assembly can be clamped tight using mounting hardware. Holes for this purpose are provided on the controller board and match mounting holes on most compatible flex-cable assemblies.

1.4.2 - LED connector

This connector is provided to drive up to two Ajile LED controller boards, providing all the signals necessary to control up to 6 channels of LED lighting. Normally the 4-pin interconnect cable is provided with the LED controller board, where the other interconnect cable end mates with a similar connector on this board.

1.4.3 - Trigger connector

This connector is used for trigger I/O and access to select MIO peripherals. It is normally connected to an Ajile trigger board through a 6-pin cable. This cable is connected to a similar connector on the trigger board. The trigger board also features a pass-through connector for this cable; trigger pins and power are still available to other devices even when a trigger board is installed in the system.

For devices that do not require isolated triggers, a raw cable is available which exposes the trigger signals directly – in this case the user is responsible to ensure electrical compatibility between the DMD controller and the triggering device.

Trigger pins 1 and 2 are connected to Zynq PS MIO's and provide access to MIO peripherals, and can be uniquely wired to support this. Please refer to the connector section later in this document for PS-MIO peripheral mappings and electrical specifications.

1.4.4 - USB connector

This is a USB2.0 OTG port, which provides access to the Ajile DMD controller via USB. For device usage, a standard micro-USB cable is connected between here and a USB host. If a USB-OTG adapter cable is connected here, or if a native USB-OTG device is connected, the port will act as a USB host (rather than a USB device) and provide both power and USB connectivity to the attached USB device. Note that the Ajile DMD board does not pull primary power from this USB connector in non-OTG mode, and external primary power must be applied separately to the board before USB functionality is enabled.

If an attached device in USB-OTG mode draws excessive current, a fault indicator is immediately lit to highlight the issue and sent to the DMD controller for action. This prevents damage to both the faulty USB device and the Ajile DMD controller board, and allows for remote reporting of the fault condition by the Ajile system.

1.4.5 - AJP+

The main data connection to the Ajile DMD controller is provided through a 51-pin flat-flex cable connected to CN5. This cable has no orientation issues, and just needs to be physically connected to another AJP/AJP+ port. Since these cables are polarized and cannot be inserted incorrectly, wiring becomes simply physically connecting the cable to an appropriate port on another Ajile device.

1.4.6 - AJP Power

The Ajile DMD controller requires +4.5-5v for correct operation. Normally a 2-pin cable connecting to CN6 provides this power. Note that the board must be powered from an external power supply to operate normally and support USB operation. This is because the power bus in an Ajile DMD controller does not draw primary power from the external USB connection.

1.4.7 - microSD Card

Normally, the board will boot from internal flash when powered. A microSD card connector is available for alternate booting, and is enabled for boot when a card with a valid boot-image is inserted in the connector. When removed, the board is reconfigured to boot from internal flash once again.

1.5 - Indicators

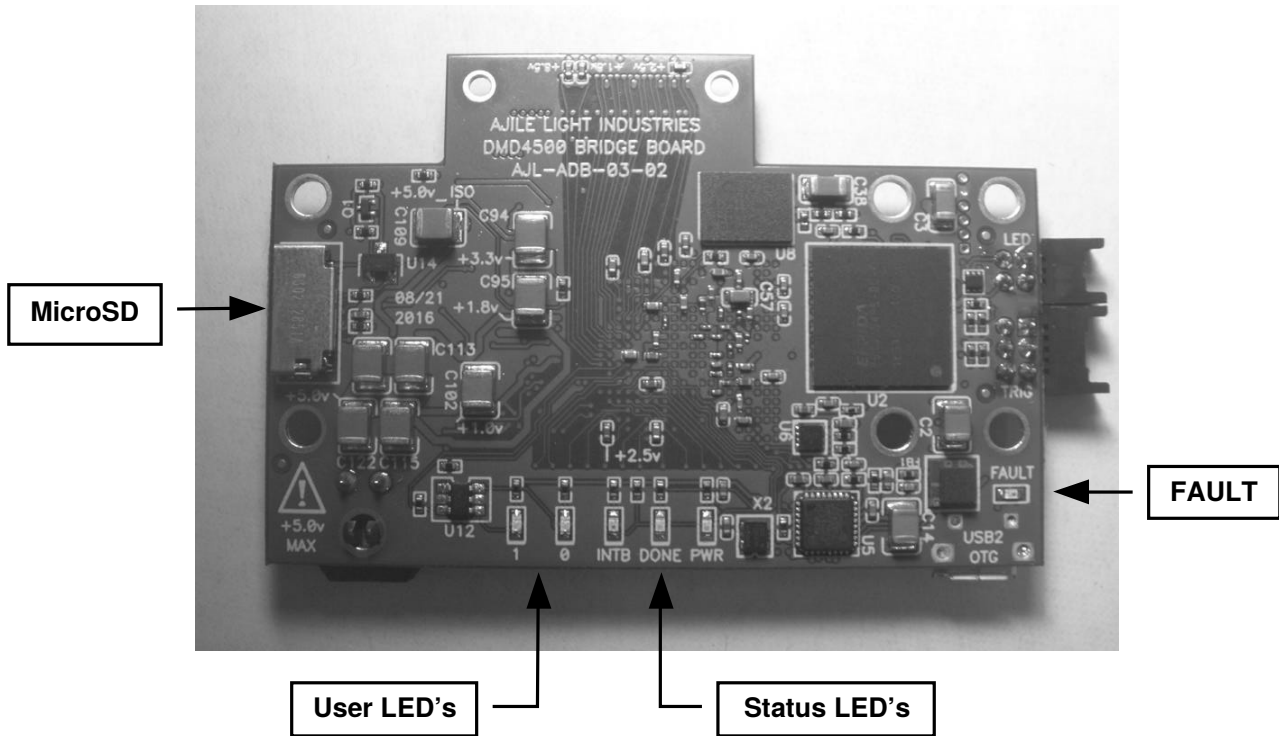

1.5.1 - Overview of indicators

A number of LED indicators are present on the Ajile DMD controller to indicate board state. These indicators are summarized as follows:

Ajile DMD Controller LED Indicators

LED	Colour	Function
PWR	Green	Indicates state of 3.3v board internal main power
DONE	Blue	Indicates Zynq 'DONE' state as part of initial configuration
INTB	Red	Indicates Zynq 'INIT B' state as part of initial configuration
0	Violet	User LED 0 – driven by application code
1	Violet	User LED 1 – driven by application code
FAULT	Red	Indicates a power surge on the USB2.0 port in OTG mode

1.5.2 - Boot-mode indicators – normal startup

Under normal conditions during power up, the PWR light will light first indicating the main board 3.3v power supply has successfully started. Almost immediately, the INTB LED will flash briefly and then go dark. After a short pause (as code is loaded into the Zynq), the DONE LED will light a steady blue to indicate successful configuration of the device. If the Zynq boot process is somehow interrupted, the final state of these two indicators can be an aid towards diagnosing boot issues.

*For more information on the usage of 'INIT B' and 'DONE' and their specific application during the Zynq boot process, please refer to the document **UG585 – Zynq-7000 All Programmable SoC Technical Reference Manual** for complete details.*

1.5.3 - USB Fault indicator

The FAULT LED will light if there is a USB power fault (over-current) in USB-OTG mode. This indicator is unused in USB device mode. In any instance this fault indicator is lit, a problem exists within the USB port and should be addressed regardless of port mode. If removing the USB cable does not correct the condition while operating under known software conditions, the DMD controller board is at fault and should be replaced.

1.5.4 - User indicators

User LED's are fully under control of the application code, and are connected to Zynq PL pins. Since these are application-driven, their usage is unique to the code running on the DMD controller and it is this application code which defines their usage. Please refer to the relevant application document for these details.

1.6 - Thermal monitoring

A thermal monitor is available as part of the Zynq processor core. This source reports board temperature to the application running on the system for monitoring purposes. This is the only source of board temperature data available on the Ajile DMD controller board.

1.7 - Power monitoring for DMD power sequencing

Power state is monitored internally to provide a compatible run-state for the DMD device, as there are severe constraints on sequencing power for correct operation. This is handled through a combination of hardware fail-safes and application code, but the net result is that DMD power sequencing is handled automatically by software control, with certain critical power states controlled by fail-safe logic to prevent damage to the DMD under all power conditions. This prevents DMD damage in the case that rogue application software incorrectly sequences DMD power. Additionally, there is an 'early' power fail indicator used to indicate loss of primary power while still maintaining enough energy to allow some Zynq run-time and allow for an orderly shut-down of DMD operation.

Please visit <https://ajile.ca/support/>

and [log in](#) or [register](#)

to download full document text

